

# **HOTLOK®**

## HotLok® Blanking Panels

### Part Numbers

Black 1U - 10031

Black 2U - 10033



## Applications

Designed to effectively seal openings in IT equipment cabinets and control airflow for optimized cooling effectiveness. The HotLok Blanking Panel reduces hotspots and bypass airflow by preventing equipment exhaust air or hot aisle air from migrating to the conditioned air intake stream at the front of the cabinet. HotLok Blanking Panels are available in both 1U and 2U configurations and a choice of traditional black or a more reflective white.

The white blanking panels are available to coordinate with white racks and enclosures for improved aesthetics. In addition, they are engineered to offer light reflectance properties for energy savings by increasing the reflectivity in the server cabinet and reducing the amount of lighting required. At normal data center lighting levels, the white blanking panel offers 3.5 times the reflectance of a standard black blanking panel. This means more brilliancy in the data center and better illumination of surrounding surfaces and computer cabinets.

## Features

- Cantilevered sealing vanes eliminate the gap between adjoining blanking panels or with installed equipment to provide the most effective sealing blanking panel on the market, a seal 29% better than the nearest competitor

## Features (Continued)

- Tool-free, snap-in installation requires no additional parts or components for installation
- Ergonomic finger grips built in to allow easy-pull removal in standard EIA-310-E openings
- Interlocking design allows secure stacking (1U panels stack 10 high and 2U panels stack 20 high) for easy storage and convenient carrying, supporting the best practice of keeping particulates and contaminants like cardboard boxes out of the data center
- Compliant with Directive 2002/95/EC of the European Parliament and the Council on the Restriction of the Use of Certain Hazardous Substances in the Electrical and Electronic Equipment (RoHS)

## Benefits

- Allows lower temperature air to be delivered to the upper one-third of the cabinet, typically the hottest area and most prone to equipment failure
- Use in a Hot and Cold Aisle configuration for low or high density cabinets
- Controls airflow that could lead to saved energy by allowing adjustment of cooling unit set points
- Use in existing cabinets for optimization and standardization
- 1U and 2U versions available for EIA-310-E compliant cabinets

# Specifications

Dimensions	Inches	Millimeters
Part No. 10031 - 1U - Overall size (length x height)	19" x 1.75"	482.5 x 44.45mm
Part No. 10033 - 2U - Overall size (length x height)	19" x 3.5"	482.5 x 89mm

## Patented Rack Sealing System

U.S. design patent number D577,360 and multiple International design patents. U.S. and International utility patents pending.



Winner of the Best Product Award in the Infrastructure category. Searchdatacenter.com

## Materials

Black (Part No. 10031 & 10033)  
Recyclable ABS (Acrylonitrile Butadiene Styrene)



Fire Resistant - ABS is rated UL94 HB

## Colors

10031 & 10033 - Black (ABS)

## 1U Product Image

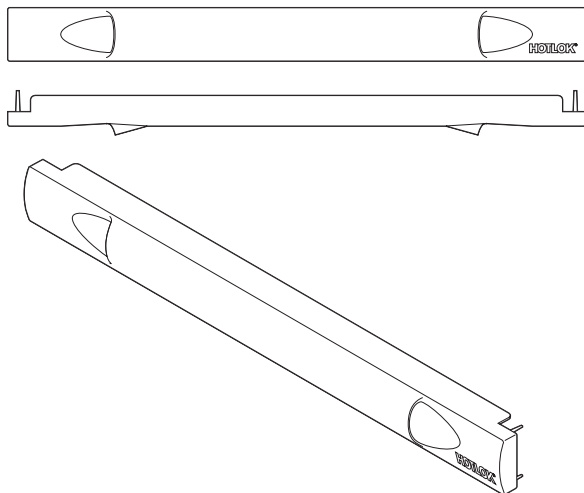

## 2U Product Image

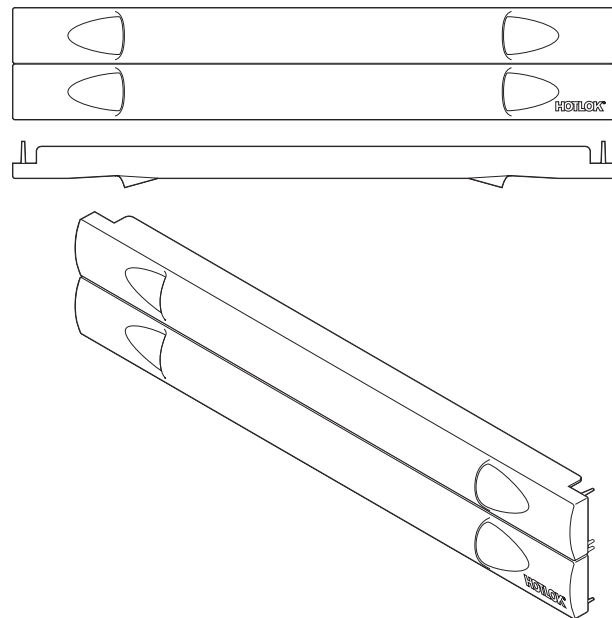

Geist Americas  
1821 Yolande Ave  
Lincoln, NE 68521  
1.800.432.3219  
402.474.3400  
www.geistglobal.com