

SA1-01002XLNB Installation Guide

SwitchAir 1U Network Switch Cooling

For Rear Air Intake-Front (Port) Exhaust Switches

Installation Precaution:

- Install SwitchAir such that the required airflow for safe operation of equipment is not compromised.
- Take precaution to avoid interference with the switch input power cords when installing on a live unit.

SwitchAir 1U Installed in Rack

Installs in minutes while network switch is live.

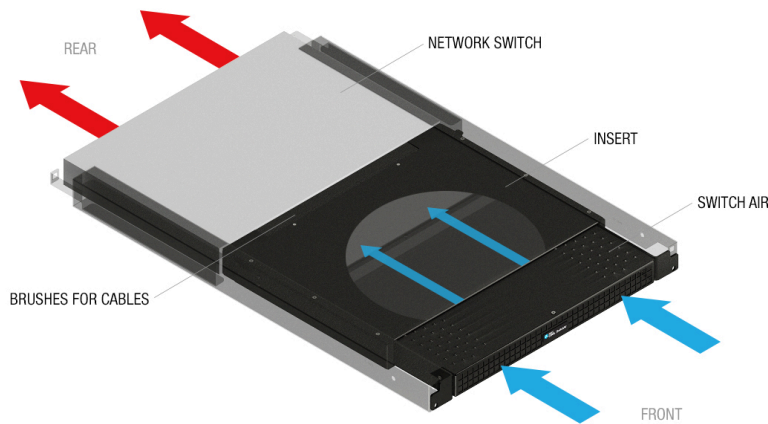

SA1-01002XLNB Specifications	
Rail Depth Range	28 1/2" to 30"
Chassis/Extender Depth	12 3/4" to 21"
Airflow	Passive (Switched Generated)
Switch Intake	Rear/Front
Warranty	Lifetime
XLNB Option Includes	Extra Long Insert with New Build Side Rails

Installing the SwitchAir

(1) Mount the adjustable rails using customer provided cage nuts and screws. The new build rails will be used to support the network switch, SwitchAir chassis and insert. Attach the new rails using only the top front screw holes on both rack front rails. The rail extension tab attaches to the rack rear using a single cage nut and screw. Use the center hold of the 1U space for this attachment.

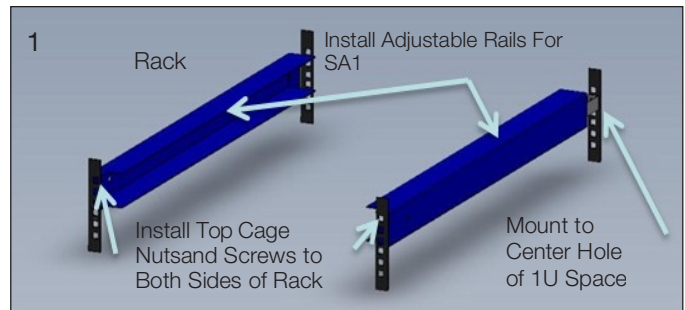

(2) Slide the network switch into the rails and mount to the rack using customer provided cage nuts and screws.

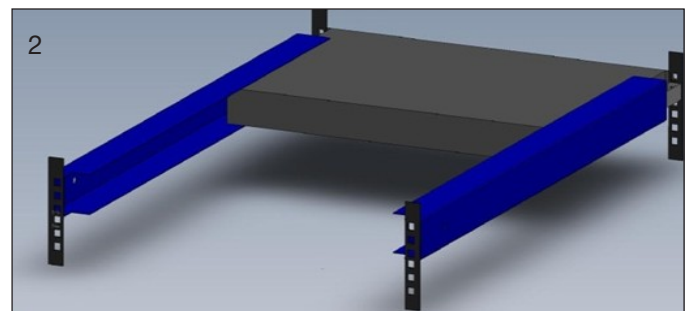

(3) SwitchAir is not in the fully extended position when shipped from the factory. Pull evenly on the chassis mounting tabs for the desired depth.

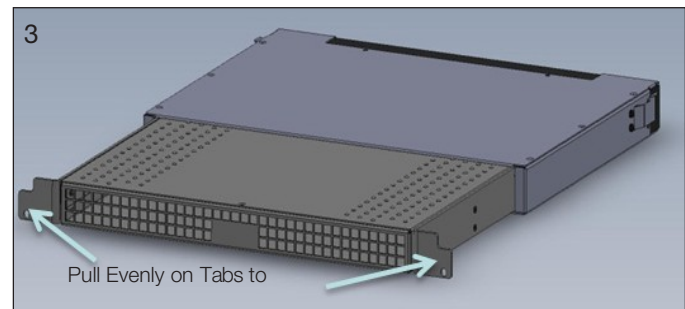

(4) Insert SA1 into the rails and push unit until the insert comes into contact with the network switch and the chassis tabs are in contact with the rack. During this process route the cables through the brush openings. Install the bottom SA1 chassis screws on both sides.

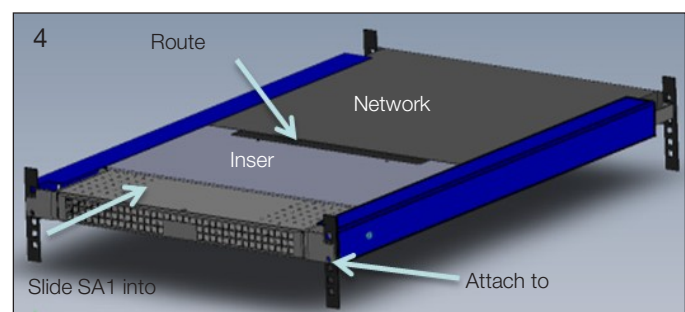

Install is complete.