

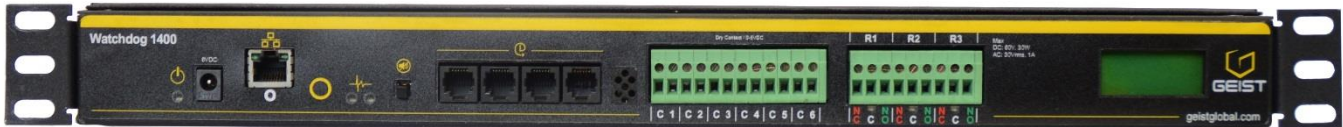

Instruction Manual
Environmental Monitoring Unit with Output Relays

Watchdog 1400 Series
Firmware Version 3



Contents

Contents	2
Specifications	3
Overview	3
Environmental	3
Electrical	3
Output Relay Contact Ratings	3
Networking	4
Data Formats	4
EMC Verification	4
Installation	5
Guidelines	5
Mounting	5
Network Overview	5
Default IP Address	5
Initial Setup	6
Web Interface.....	8
Overview	8
Sensors Page	8
Logging Page	10
Display Page	11
Alarms Page	13
Configuration Page	14
Control Page	19
Unit Configuration	20
Network Configuration	20
Time and Date	21
E-Mail	21
SNMP	23
Accounts and Passwords	23
Telnet	24
Camera Configuration	24
Admin Information	25
Output Relays	26
Relay Contact Ratings	26
Relay Settings	26
Manual Override	26
Acknowledgments	26
Alarms	28
Alarm Notifications	28
Alarm Types	28
Thresholds	28
Sensors.....	29
Overview	29
Internal Sensors	29
I/O Sensors	29
Remote Sensors	31
Data Logging and Display	31
Accessories.....	32
IP-Addressable Network Cameras	32
RSC Integration	32
Alternate Data Formats	32
Technical Support.....	33
Firmware Version	33
Firmware Updates	33
Resetting the Unit	33
Service and Maintenance	33
More Technical Support	33
Table of Figures	34
Revision History	35

Specifications

Overview

The Watchdog 1400 Environmental Monitoring and Output Units provide remote environmental monitoring and alarming capability needed to detect climate conditions in data centers. Additionally, the Watchdog 1400 provides three output relays that can be operated remotely or set to automatically open or close based on alarm conditions. The Watchdog 1400 units are equipped with a built-in web server. Web pages, including graphs, are generated by the unit to monitor environmental conditions within the cabinet. The Web pages are also used to control the output relays. No software other than a web browser is required for operation and several data formats are available. The Watchdog 1400 has a built-in sensor to monitor temperature as well as four ports for optional external sensors. The Watchdog 1400 Series also has six I/O ports for connecting additional external sensors such as Water and Door Sensors. The Watchdog 1400 has a scrolling LCD display and built-in alarm buzzer.

Environmental

Temperature

Operating:	10°C (50°F) min	45°C (104°F) max
Storage:	-25°C (-13°F) min	65°C (149°F) max

Humidity

Operating:	5% min	95% max	(non-condensing)
Storage:	5% min	95% max	(non-condensing)

Elevation

Operating:	0 m (0 ft) min	2000 m (6561 ft) max
Storage:	0 m (0 ft) min	15240 m (50000 ft) max

Electrical

6 Volts DC, 2 Amps

Output Relay Contact Ratings

The output relay contacts are intended to carry low voltage signals only. Do not exceed the following ratings on the output relay contacts:

DC: 60 V, 30 W

AC: 30 Vrms, 1 A

Warning: Consideration should be given to lockout-tagout and other procedures required for servicing external devices controlled by the Watchdog 1400 output relays. Appropriate safety precautions must always be taken when operating or maintaining equipment connected to the Watchdog 1400. Geist Manufacturing assumes no responsibility or liability for any injury or damage to any persons or property resulting from improper operation or maintenance of a device connected to the Watchdog 1400.

Caution: The Watchdog 1400 unit has not been evaluated for and should not be used in any application in which the failure of the Hardware could lead to death, personal injury or severe physical or property damage or environmental damage (collectively, “High-Risk Applications”), including but not limited to the operation of nuclear facilities, mass transit systems, aircraft navigation or aircraft communication systems, air traffic control, weapon systems and direct life support machines. Geist expressly disclaims any express or implied warranty or condition of fitness for High-Risk Applications.

Networking

Protocols

HTTP, HTTPS (SSL/TLS), SMTP, POP3, ICMP, DHCP, TCP/IP, NTP, Telnet, Syslog

Ethernet Link Speed

10 Mbit; half-duplex

Data Formats

HTML, SNMP, CSV/Plain Text, XML

EMC Verification

This Class A device complies with part 15 of the FCC Rules. Operation is subject to the following two conditions: (1) This device may not cause harmful interference, and (2) this device must accept any interference received, including interference that may cause undesired operation.

This Class A digital apparatus complies with Canadian ICES-003.

Cet appareil numérique de la classe A est conforme à la norme NMB-003 du Canada.

Warning: Changes or modifications to this unit not expressly approved by the party responsible for compliance could void the user’s authority to operate this equipment.

Installation

Guidelines

- If the Watchdog 1400 is installed in a cabinet the ambient temperature of the rack should be no greater than 45°C.
- Install the Watchdog 1400 such that the amount of airflow required for safe operation of equipment is not compromised.
- Mount the Watchdog 1400 so that a hazardous condition is not achieved due to uneven mechanical loading.

Mounting

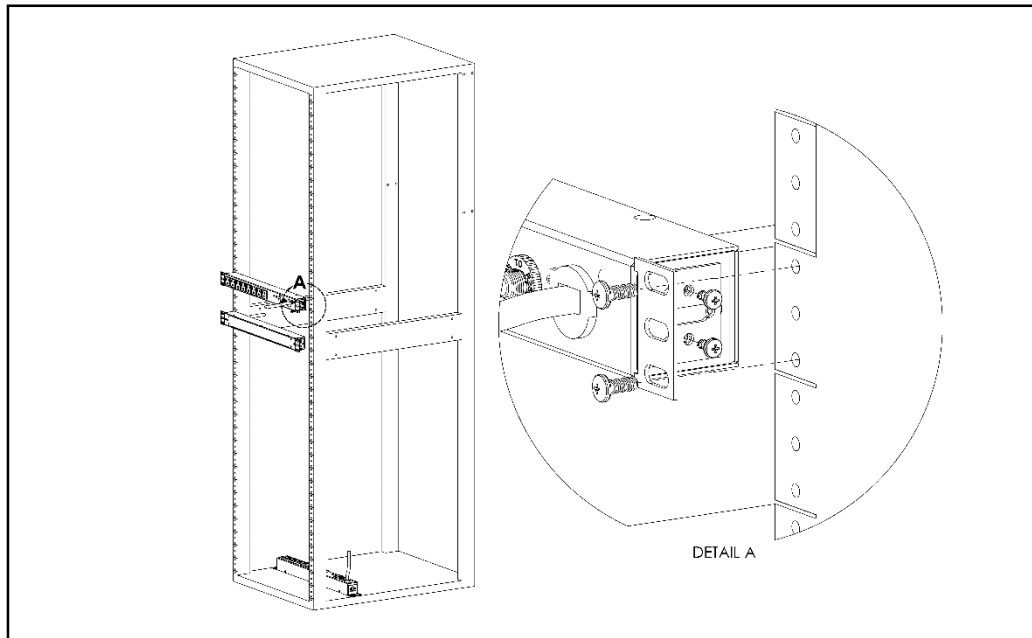

Figure 1: 19" Horizontal/Panel Mount Brackets (7938)

Using the 19" horizontal/panel mount brackets, attach unit to rack as shown

Network Overview

This product comes preconfigured with a default IP address set. Simply connect to the Environmental Monitoring Unit and access the web page with your browser.

Default IP Address

Watchdog 1400 units have a default IP address for initial setup and access to the unit if the assigned address is lost or forgotten. Once an IP address is assigned to a unit, the default IP address is no longer active. To restore the default IP address, press the reset button located below the network connector and hold for approximately 20 seconds. The idle and activity lights on the network connector will both light up when the IP address has been reset. The reset button is accessed through the white, circular hole located below the Ethernet jack.

Note: Pressing the reset button under the network connector will restore the default IP address and will also clear all password settings.

The Configuration page allows you to assign the network properties or use DHCP to connect to your network. Access to the unit requires the IP address to be known, so use of a Static IP or reserved DHCP is recommended. The default address is shown on the front of the unit:

- **IP Address:** 192.168.123.123
- **Subnet Mask:** 255.255.255.0
- **Gateway:** 192.168.123.1

Initial Setup

Connect the Watchdog 1400 to your computer using a crossover cable or hub/switch.

Windows OS

Navigate to the Local Area Network Adapter Connections Properties and change the Internet Protocol Version 4 (TCP/IPv4) Properties. Select "Use the following IP address". Use these settings:

- **IP Address:** 192.168.123.1
- **Subnet Mask:** 255.255.255.0
- **Gateway:** Leave blank

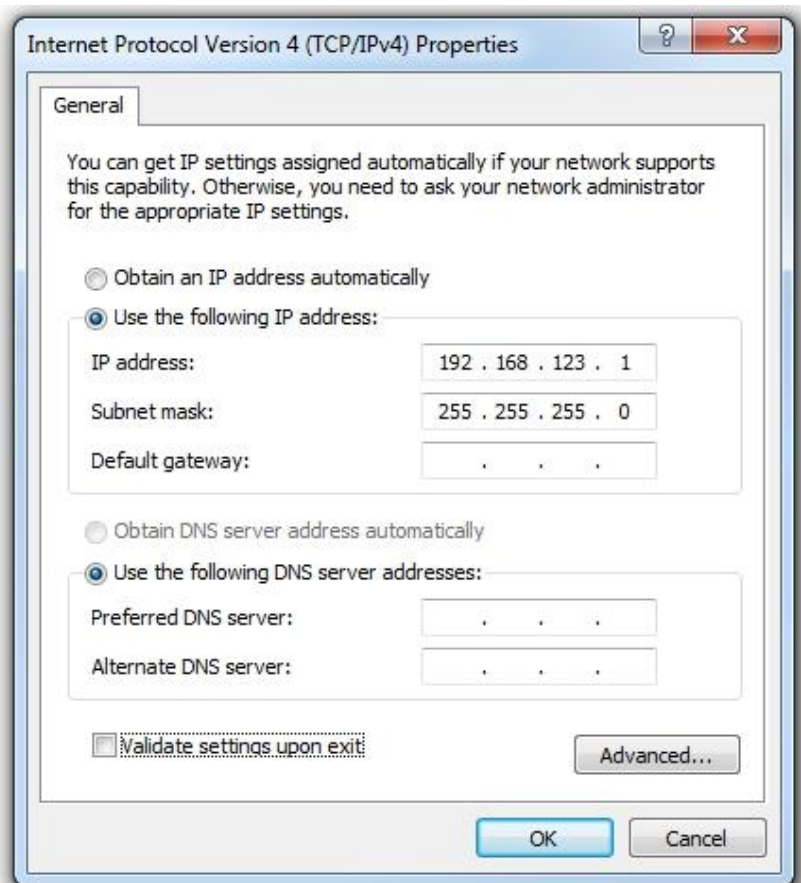

Figure 2: Network settings for initial setup. Images varies depending on Windows versions.

Save changes.

The unit should now be accessible in a web browser via the unit's permanent IP address: <http://192.168.123.123/>. See Unit Configuration (page 20) for details.

Mac OS

Open System Preferences via the Dock or the Apple menu.

Select "Network" under "Internet & Network."

Select "Ethernet" from the list on the left side of the window and enter these settings on the right side of the window:

- **Configure:** Manually
- **IP Address:** 192.168.123.1
- **Subnet Mask:** 255.255.255.0
- **Router:** Leave blank

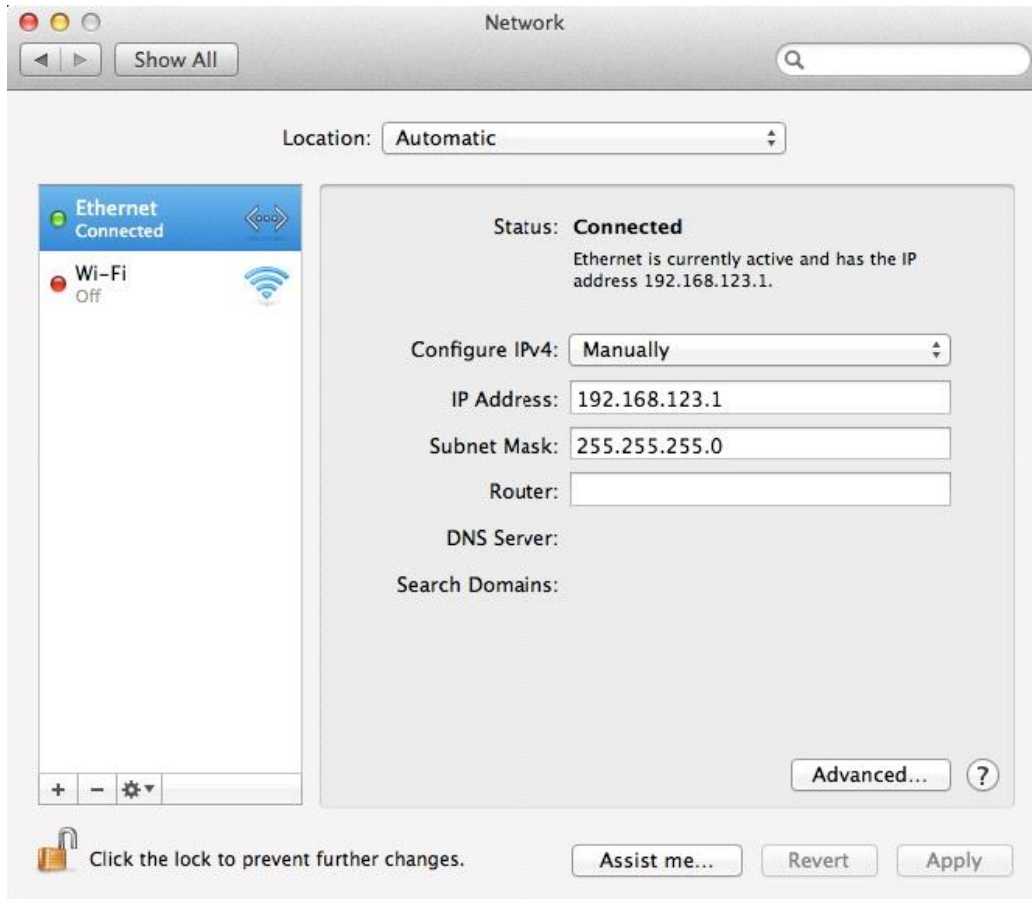

Figure 3: Mac OS network settings for initial setup. Image varies depending on Mac versions.

Apply changes.

The unit should now be accessible in a web browser via the unit's permanent IP address: <http://192.168.123.123/>. See Unit Configuration (page 20) for details.

Web Interface

Overview

The unit is accessible via a standard, unencrypted HTTP connection as well as an encrypted HTTPS (SSL) connection. The following web pages are available:

Sensors Page

The front page, *Sensors*, gives both instantaneous and historical views of the unit's data. Real time readings are provided for all sensor data next to historical graphs.

Optional cameras may be added and their live snapshots are shown on this page. Plug-and-play external sensors appear below the internal sensors when attached.

The menu bar allows access to the rest of the Environmental Monitoring Unit's functionality.

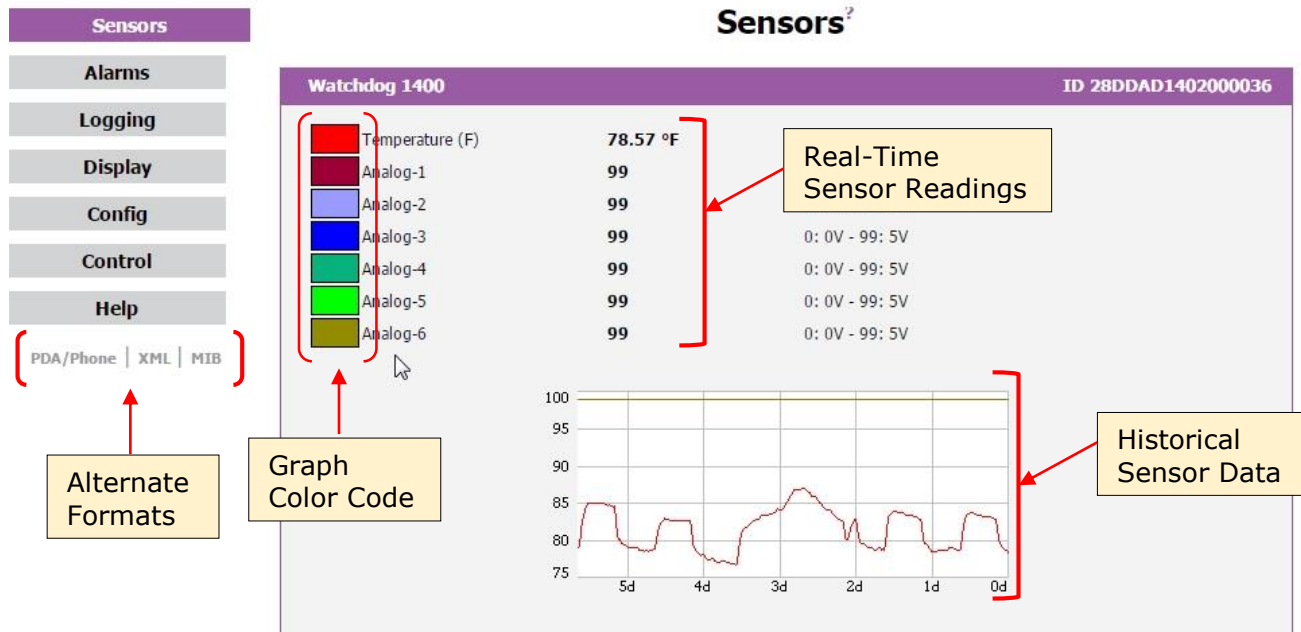
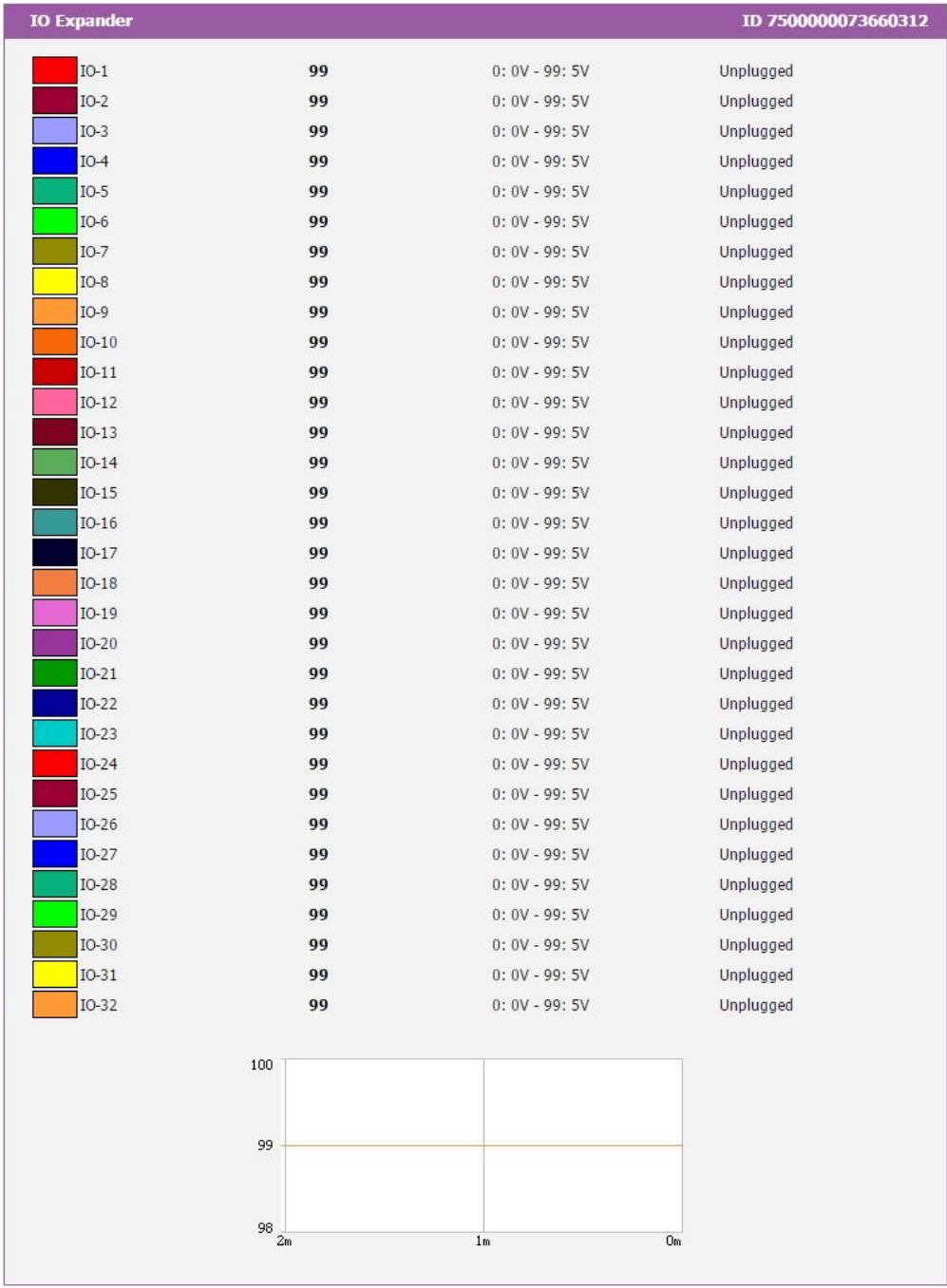

Figure 4: Sensors Page – Internal Sensor and I/O Data



English | Français | 中文 | Deutsch | 日本語 | Español

Figure 5: Sensors Page – External Sensor Data

Logging Page

The *Logging* page allows the user to access the historical data by selecting the desired sensors and time range to be graphed. All sensor values that can be graphed are logged into the data file at a rate of one point per minute. Please note that although data is logged once per minute, all sensor data used in the real time display and alarm functions is read at least once every 5 seconds for internal sensors and once every 30 seconds for external sensors. Checked readings are displayed on the LCD module. Recorded data is available for download in a comma-separated values (CSV) file.

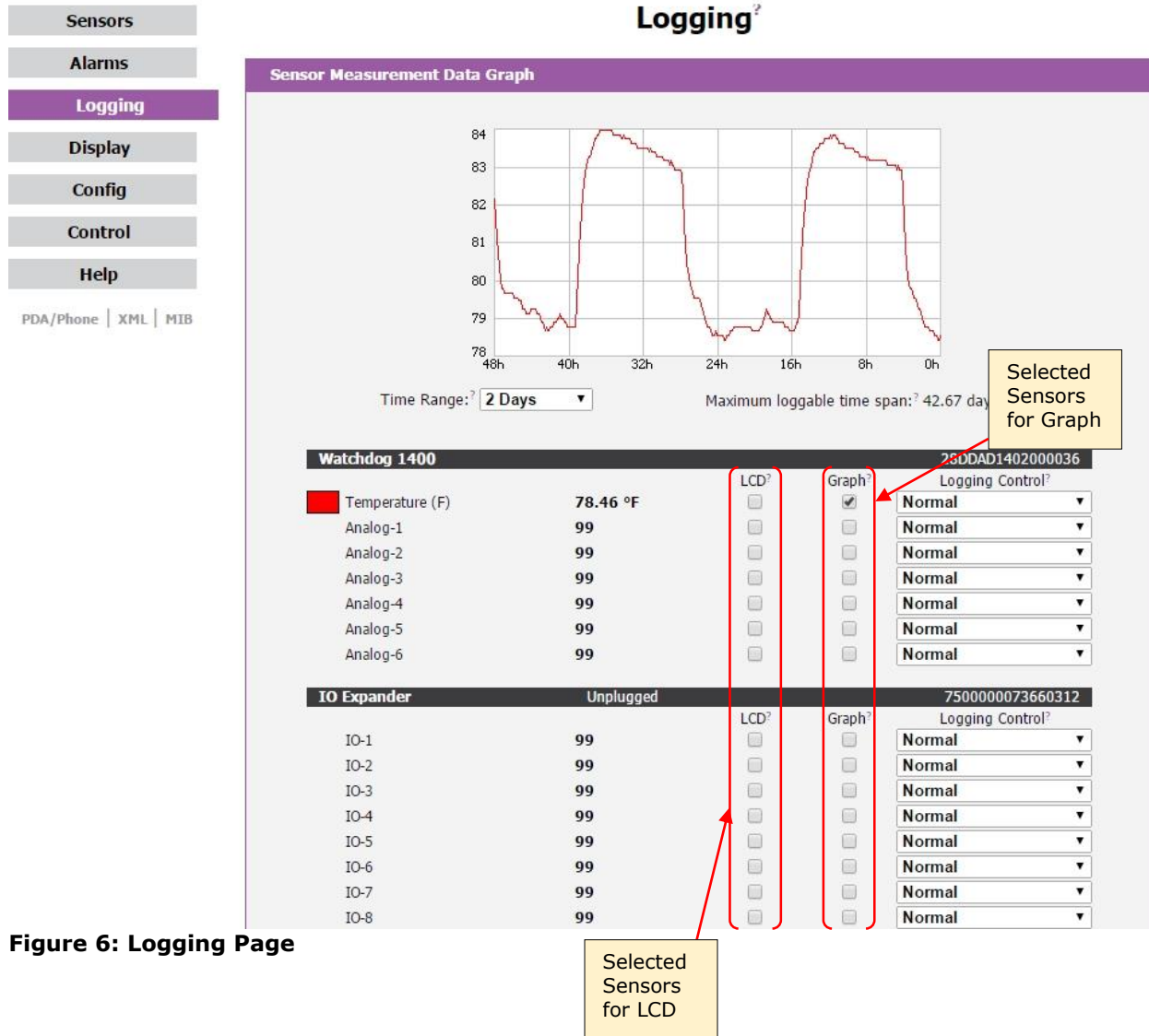

Figure 6: Logging Page

Display Page

The *Display* page allows the user to assign friendly names to internal and attached sensors as well as change the default temperature unit of measure for sensors. The display page also allows the user to select between the default and classic web page layouts. The default interface displays a vertical menu bar to the left of the main window, while the classic interface displays a horizontal menu bar across the top of the screen.

The screenshot shows the 'Display' page interface. On the left is a vertical navigation menu with options: Sensors, Alarms, Logging, Display (highlighted), Main, IO Expander, Config, Control, and Help. Below the menu are links for PDA/Phone, XML, and MIB. The main content area is titled 'Display' and contains three sections:

- General:** Configuration options for Default Language (English), Date Format (USA (MM/DD/YY)), Temperature Unit (Fahrenheit), Internal Temperature Offset (0), Interface Type (Default), and Scroll on LCD (Measurements). A 'Save Changes' button is at the bottom.
- Devices:** A table listing devices with columns for Unique Address, Device Type, and Friendly Name. Two devices are shown: 'climateRelay' (Watchdog 1400) and 'ioExpander' (IO Expander). A red 'Unplugged' status is shown next to the IO Expander. A checkbox for 'Remove all unplugged devices' and a 'Save Changes' button are also present.
- Analog Sensors:** A table for configuring analog sensors. A red circle highlights the 'Min' and 'Max' columns, and a yellow box labeled 'Analog Scale Adjustment' points to the 'Unit' column.

Sensor	Friendly Name	Min	Max	Unit
IO-1	Analog-1	0.000	99.000	
IO-2	Analog-2	0.000	99.000	
IO-3	Analog-3	0.000	99.000	
IO-4	Analog-4	0.000	99.000	
IO-5	Analog-5	0.000	99.000	
IO-6	Analog-6	0.000	99.000	

Figure 7: Display Main Page

- Sensors
- Alarms
- Logging
- Display**
- Main
- IO Expander
- Config
- Control
- Help

PDA/Phone | XML | MIB

Display²

General

Default Language:[?] ▾

Date Format:[?] ▾

Temperature Unit: ▾

Internal Temperature Offset:[?] ▾

Interface Type:[?] ▾

Scroll on LCD:[?] ▾

Devices

Unique Address	Device Type	Friendly Name	
28DDAD1402000036	climateRelay	<input type="text" value="Watchdog 1400"/>	
7500000073660312	ioExpander	<input type="text" value="IO Expander"/>	Unplugged

Remove all unplugged devices

Analog Sensors

Sensor	Friendly Name	Min	Max	Unit
IO-1	<input type="text" value="Analog-1"/>	<input type="text" value="0.000"/>	<input type="text" value="99.000"/>	<input type="text"/>
IO-2	<input type="text" value="Analog-2"/>	<input type="text" value="0.000"/>	<input type="text" value="99.000"/>	<input type="text"/>
IO-3	<input type="text" value="Analog-3"/>	<input type="text" value="0.000"/>	<input type="text" value="99.000"/>	<input type="text"/>
IO-4	<input type="text" value="Analog-4"/>	<input type="text" value="0.000"/>	<input type="text" value="99.000"/>	<input type="text"/>
IO-5	<input type="text" value="Analog-5"/>	<input type="text" value="0.000"/>	<input type="text" value="99.000"/>	<input type="text"/>
IO-6	<input type="text" value="Analog-6"/>	<input type="text" value="0.000"/>	<input type="text" value="99.000"/>	<input type="text"/>

Analog Scale Adjustment

Figure 8: Display IO Expander Page

Alarms Page

The *Alarms* page allows the user to establish alarm conditions for each sensor reading. Alarm conditions can be established with either high or low trip thresholds. The alarms are displayed in different sections based on the sensor the alarm is associated with. Alarm options include relays, a local Buzzer, Email and SNMP Traps. See Alarms (page 28) for details.

The screenshot displays the 'Alarms' configuration page. On the left is a navigation menu with 'Alarms' selected. The main content area is titled 'Alarms' and contains three sections:

- Watchdog 1400 (ID 28DDAD1402000036):** This section allows configuring an alarm for Temperature (C). The alarm trips if the temperature is 'Below' a threshold of -999.0. The alarm must remain tripped for 0 minutes before notification. The repeat interval is set to 'No Repeat'. There are three email notification options: (E-mail 1), (E-mail 2), and (E-mail 3). A green 'Untripped' button is present. 'Save Changes' and 'Add New Alarm' buttons are at the bottom.
- IO Expander (ID 7500000073660312):** This section contains an 'Add New Alarm' button.
- Alarm Behavior:** This section has a dropdown for 'Unplugged Alerts?' set to 'Enabled' and a 'Save Changes' button.

At the bottom left of the page, there are links for 'PDA/Phone', 'XML', and 'MIB'.

Figure 9: Alarms Page

Configuration Page

The *Configuration* page has five sub-tabs; *Network*, *Monitoring*, *Diagnostics*, *Event Log*, and *Admin*. See Unit Configuration (page 20) for details.

Configuration Network Tab

The user can enter and update the network settings on the *Network* tab of the *Configuration* page. See Unit Configuration section for details.

The screenshot displays the 'Configuration' page with a sidebar on the left containing navigation tabs: Sensors, Alarms, Logging, Display, Config (highlighted), Network (highlighted), Monitoring, Diagnostics, Event Log, Admin, Control, and Help. Below the sidebar are links for PDA/Phone, XML, and MIB. The main content area is titled 'Configuration' and contains two sections: 'Network' and 'Web Server'. The 'Network' section shows 'Current Network Configuration set statically' with a link speed of '10Mbps/half-duplex'. It offers three radio button options: 'Use DHCP for Network Configuration and DNS Server Addresses', 'Use DHCP for Network Configuration and Static DNS server addresses', and 'Use Static Network Configuration and DNS server addresses' (which is selected). Below these are input fields for IP Address (192.168.140.221), Subnet Mask (255.255.255.0), Gateway (192.168.140.254), Primary DNS Server (8.8.8.8), and Secondary DNS Server (8.8.4.4). A 'Save Changes' button is at the bottom right. The 'Web Server' section has a dropdown for Protocols (HTTP and HTTPS), input fields for HTTP Port (80) and HTTPS Port (443), and a dropdown for Telnet Service (Enabled). A 'Save Changes' button is also present at the bottom right.

Figure 10: Configuration Network Tab

Configuration Diagnostics Tab

The user can update the Syslog settings on the *Diagnostics* tab of the *Configuration* page.

The screenshot shows the 'Configuration' page with a sidebar on the left containing navigation tabs: Sensors, Alarms, Logging, Display, **Config**, Network, Monitoring, **Diagnostics**, Event Log, Admin, Control, and Help. Below the sidebar are links for PDA/Phone, XML, and MIB.

The main content area is titled 'Configuration' and contains two sections:

- Syslog**: A form with a 'Facility' dropdown menu set to 'LOCAL0' and a 'Daemon Address:port 1:' text input field. A 'Save Changes' button is located below the input field.
- Syslog Configuration**: A table with columns for 'Subsystems' and 'Severity'. The severity levels are emergency, alert, critical, error, warning, notice, inform, and debug. Each subsystem has a row of checkboxes corresponding to these severity levels. A 'Save Changes' button is located at the bottom of the table.

Subsystems	Severity							
	emergency	alert	critical	error	warning	notice	inform	debug
os	<input checked="" type="checkbox"/>	<input checked="" type="checkbox"/>	<input checked="" type="checkbox"/>	<input checked="" type="checkbox"/>	<input type="checkbox"/>	<input type="checkbox"/>	<input type="checkbox"/>	<input type="checkbox"/>
lwip	<input checked="" type="checkbox"/>	<input checked="" type="checkbox"/>	<input checked="" type="checkbox"/>	<input checked="" type="checkbox"/>	<input type="checkbox"/>	<input type="checkbox"/>	<input type="checkbox"/>	<input type="checkbox"/>
socket	<input checked="" type="checkbox"/>	<input checked="" type="checkbox"/>	<input checked="" type="checkbox"/>	<input checked="" type="checkbox"/>	<input type="checkbox"/>	<input type="checkbox"/>	<input type="checkbox"/>	<input type="checkbox"/>
macphy	<input checked="" type="checkbox"/>	<input checked="" type="checkbox"/>	<input checked="" type="checkbox"/>	<input checked="" type="checkbox"/>	<input type="checkbox"/>	<input type="checkbox"/>	<input type="checkbox"/>	<input type="checkbox"/>
flashfl	<input checked="" type="checkbox"/>	<input checked="" type="checkbox"/>	<input checked="" type="checkbox"/>	<input checked="" type="checkbox"/>	<input type="checkbox"/>	<input type="checkbox"/>	<input type="checkbox"/>	<input type="checkbox"/>
webserv	<input checked="" type="checkbox"/>	<input checked="" type="checkbox"/>	<input checked="" type="checkbox"/>	<input checked="" type="checkbox"/>	<input type="checkbox"/>	<input type="checkbox"/>	<input type="checkbox"/>	<input type="checkbox"/>
spi0dev	<input checked="" type="checkbox"/>	<input checked="" type="checkbox"/>	<input checked="" type="checkbox"/>	<input checked="" type="checkbox"/>	<input type="checkbox"/>	<input type="checkbox"/>	<input type="checkbox"/>	<input type="checkbox"/>
device	<input checked="" type="checkbox"/>	<input checked="" type="checkbox"/>	<input checked="" type="checkbox"/>	<input checked="" type="checkbox"/>	<input type="checkbox"/>	<input type="checkbox"/>	<input type="checkbox"/>	<input type="checkbox"/>
host	<input checked="" type="checkbox"/>	<input checked="" type="checkbox"/>	<input checked="" type="checkbox"/>	<input checked="" type="checkbox"/>	<input type="checkbox"/>	<input type="checkbox"/>	<input type="checkbox"/>	<input type="checkbox"/>
setvars	<input checked="" type="checkbox"/>	<input checked="" type="checkbox"/>	<input checked="" type="checkbox"/>	<input checked="" type="checkbox"/>	<input type="checkbox"/>	<input type="checkbox"/>	<input type="checkbox"/>	<input type="checkbox"/>
dynweb	<input checked="" type="checkbox"/>	<input checked="" type="checkbox"/>	<input checked="" type="checkbox"/>	<input checked="" type="checkbox"/>	<input type="checkbox"/>	<input type="checkbox"/>	<input type="checkbox"/>	<input type="checkbox"/>
sntp	<input checked="" type="checkbox"/>	<input checked="" type="checkbox"/>	<input checked="" type="checkbox"/>	<input checked="" type="checkbox"/>	<input type="checkbox"/>	<input type="checkbox"/>	<input type="checkbox"/>	<input type="checkbox"/>
alarms	<input checked="" type="checkbox"/>	<input checked="" type="checkbox"/>	<input checked="" type="checkbox"/>	<input checked="" type="checkbox"/>	<input type="checkbox"/>	<input type="checkbox"/>	<input type="checkbox"/>	<input type="checkbox"/>
email	<input checked="" type="checkbox"/>	<input checked="" type="checkbox"/>	<input checked="" type="checkbox"/>	<input checked="" type="checkbox"/>	<input type="checkbox"/>	<input type="checkbox"/>	<input type="checkbox"/>	<input type="checkbox"/>
rtclock	<input checked="" type="checkbox"/>	<input checked="" type="checkbox"/>	<input checked="" type="checkbox"/>	<input checked="" type="checkbox"/>	<input type="checkbox"/>	<input type="checkbox"/>	<input type="checkbox"/>	<input type="checkbox"/>
sntp	<input checked="" type="checkbox"/>	<input checked="" type="checkbox"/>	<input checked="" type="checkbox"/>	<input checked="" type="checkbox"/>	<input type="checkbox"/>	<input type="checkbox"/>	<input type="checkbox"/>	<input type="checkbox"/>
dns	<input checked="" type="checkbox"/>	<input checked="" type="checkbox"/>	<input checked="" type="checkbox"/>	<input checked="" type="checkbox"/>	<input type="checkbox"/>	<input type="checkbox"/>	<input type="checkbox"/>	<input type="checkbox"/>
datalog	<input checked="" type="checkbox"/>	<input checked="" type="checkbox"/>	<input checked="" type="checkbox"/>	<input checked="" type="checkbox"/>	<input type="checkbox"/>	<input type="checkbox"/>	<input type="checkbox"/>	<input type="checkbox"/>
graphin	<input checked="" type="checkbox"/>	<input checked="" type="checkbox"/>	<input checked="" type="checkbox"/>	<input checked="" type="checkbox"/>	<input type="checkbox"/>	<input type="checkbox"/>	<input type="checkbox"/>	<input type="checkbox"/>
firmwar	<input checked="" type="checkbox"/>	<input checked="" type="checkbox"/>	<input checked="" type="checkbox"/>	<input checked="" type="checkbox"/>	<input type="checkbox"/>	<input type="checkbox"/>	<input type="checkbox"/>	<input type="checkbox"/>
msgcatlg	<input checked="" type="checkbox"/>	<input checked="" type="checkbox"/>	<input checked="" type="checkbox"/>	<input checked="" type="checkbox"/>	<input type="checkbox"/>	<input type="checkbox"/>	<input type="checkbox"/>	<input type="checkbox"/>

Figure 12: Configuration Diagnostics Tab

Configuration Event Log Tab

The user can view the Event Log and update the Memory Syslog settings on the *Event Log* tab of the *Configuration* page.

- Sensors
- Alarms
- Logging
- Display
- Config
- Network
- Monitoring
- Diagnostics
- Event Log
- Admin
- Control
- Help

PDA/Phone | XML | MIB

Configuration

NVRAM Event Log

Click here to view NVM event log

[Clear NVM event log](#)

Memory Syslog

```

1/29/2015 23:23:35 setvars:var_init: Reading data from flash succeeded. Merged data will be written
1/29/2015 23:23:35 setvars:var_init: size of block in flash: 20524, current block 20524.
1/29/2015 23:23:35 setvars:var_init: Current firmware rev [1071], data in flash from rev [1072].
1/29/2015 23:23:35 setvars:var_init: token_read=[VARS BLOCK HERE], from address 0x80440000.
1/29/2015 23:23:35 setvars:var_netstack_push: secondary dns address set to static value: 8.8.4.4
1/29/2015 23:23:35 setvars:var_netstack_push: primary dns address set to static value: 8.8.8.8
1/29/2015 23:23:35 setvars:var_netstack_push: gateway set to 192.168.123.1.
1/29/2015 23:23:35 setvars:var_netstack_push: netmask set to 255.255.255.0.
1/29/2015 23:23:35 setvars:var_netstack_push: IP address set to 192.168.123.123.
1/29/2015 23:23:35 socket :set static IP to 192.168.123.123
1/29/2015 23:23:35 setvars:var_netstack_push: DHCP status set to 0.
1/29/2015 23:23:34 setvars:var_netstack_push: MAC address was set to 00:19:85:E0:13:68.
1/29/2015 23:23:34 setvars:var_netstack_push: secondary dns address set to static value: 8.8.4.4
1/29/2015 23:23:34 setvars:var_netstack_push: primary dns address set to static value: 8.8.8.8
1/29/2015 23:23:34 setvars:var_netstack_push: gateway set to 0.0.0.0.
1/29/2015 23:23:34 setvars:var_netstack_push: netmask set to 0.0.0.0.
1/29/2015 23:23:34 setvars:var_netstack_push: IP address set to 0.0.0.0.
1/29/2015 23:23:34 socket :set static IP to 0.0.0.0
1/29/2015 23:23:34 setvars:var_netstack_push: DHCP status set to 0.
1/29/2015 23:23:34 setvars:var_netstack_push: MAC address was set to 00:19:85:E0:13:68.
                    
```

Memory Syslog

Subsystems	Severity							
	emergency	alert	critical	error	warning	notice	inform	debug
os	<input type="checkbox"/>	<input type="checkbox"/>	<input type="checkbox"/>	<input type="checkbox"/>	<input type="checkbox"/>	<input type="checkbox"/>	<input type="checkbox"/>	<input type="checkbox"/>
lwip	<input type="checkbox"/>	<input type="checkbox"/>	<input type="checkbox"/>	<input type="checkbox"/>	<input type="checkbox"/>	<input type="checkbox"/>	<input type="checkbox"/>	<input type="checkbox"/>
socket	<input type="checkbox"/>	<input type="checkbox"/>	<input type="checkbox"/>	<input type="checkbox"/>	<input type="checkbox"/>	<input type="checkbox"/>	<input type="checkbox"/>	<input type="checkbox"/>
macphy	<input type="checkbox"/>	<input type="checkbox"/>	<input type="checkbox"/>	<input type="checkbox"/>	<input type="checkbox"/>	<input type="checkbox"/>	<input type="checkbox"/>	<input type="checkbox"/>
flashfl	<input type="checkbox"/>	<input type="checkbox"/>	<input type="checkbox"/>	<input type="checkbox"/>	<input type="checkbox"/>	<input type="checkbox"/>	<input type="checkbox"/>	<input type="checkbox"/>
webserv	<input type="checkbox"/>	<input type="checkbox"/>	<input type="checkbox"/>	<input type="checkbox"/>	<input type="checkbox"/>	<input type="checkbox"/>	<input type="checkbox"/>	<input type="checkbox"/>
spi0dev	<input type="checkbox"/>	<input type="checkbox"/>	<input type="checkbox"/>	<input type="checkbox"/>	<input type="checkbox"/>	<input type="checkbox"/>	<input type="checkbox"/>	<input type="checkbox"/>
device	<input type="checkbox"/>	<input type="checkbox"/>	<input type="checkbox"/>	<input type="checkbox"/>	<input type="checkbox"/>	<input type="checkbox"/>	<input type="checkbox"/>	<input type="checkbox"/>
host	<input type="checkbox"/>	<input type="checkbox"/>	<input type="checkbox"/>	<input type="checkbox"/>	<input type="checkbox"/>	<input type="checkbox"/>	<input type="checkbox"/>	<input type="checkbox"/>
setvars	<input type="checkbox"/>	<input type="checkbox"/>	<input type="checkbox"/>	<input type="checkbox"/>	<input type="checkbox"/>	<input type="checkbox"/>	<input type="checkbox"/>	<input type="checkbox"/>
dynweb	<input type="checkbox"/>	<input type="checkbox"/>	<input type="checkbox"/>	<input type="checkbox"/>	<input type="checkbox"/>	<input type="checkbox"/>	<input type="checkbox"/>	<input type="checkbox"/>
snmp	<input type="checkbox"/>	<input type="checkbox"/>	<input type="checkbox"/>	<input type="checkbox"/>	<input type="checkbox"/>	<input type="checkbox"/>	<input type="checkbox"/>	<input type="checkbox"/>
alarms	<input type="checkbox"/>	<input type="checkbox"/>	<input type="checkbox"/>	<input type="checkbox"/>	<input type="checkbox"/>	<input type="checkbox"/>	<input type="checkbox"/>	<input type="checkbox"/>
email	<input type="checkbox"/>	<input type="checkbox"/>	<input type="checkbox"/>	<input type="checkbox"/>	<input type="checkbox"/>	<input type="checkbox"/>	<input type="checkbox"/>	<input type="checkbox"/>
rtclock	<input type="checkbox"/>	<input type="checkbox"/>	<input type="checkbox"/>	<input type="checkbox"/>	<input type="checkbox"/>	<input type="checkbox"/>	<input type="checkbox"/>	<input type="checkbox"/>
sntp	<input type="checkbox"/>	<input type="checkbox"/>	<input type="checkbox"/>	<input type="checkbox"/>	<input type="checkbox"/>	<input type="checkbox"/>	<input type="checkbox"/>	<input type="checkbox"/>
dns	<input type="checkbox"/>	<input type="checkbox"/>	<input type="checkbox"/>	<input type="checkbox"/>	<input type="checkbox"/>	<input type="checkbox"/>	<input type="checkbox"/>	<input type="checkbox"/>
datalog	<input type="checkbox"/>	<input type="checkbox"/>	<input type="checkbox"/>	<input type="checkbox"/>	<input type="checkbox"/>	<input type="checkbox"/>	<input type="checkbox"/>	<input type="checkbox"/>
graphin	<input type="checkbox"/>	<input type="checkbox"/>	<input type="checkbox"/>	<input type="checkbox"/>	<input type="checkbox"/>	<input type="checkbox"/>	<input type="checkbox"/>	<input type="checkbox"/>
firmwar	<input type="checkbox"/>	<input type="checkbox"/>	<input type="checkbox"/>	<input type="checkbox"/>	<input type="checkbox"/>	<input type="checkbox"/>	<input type="checkbox"/>	<input type="checkbox"/>
msgcatlg	<input type="checkbox"/>	<input type="checkbox"/>	<input type="checkbox"/>	<input type="checkbox"/>	<input type="checkbox"/>	<input type="checkbox"/>	<input type="checkbox"/>	<input type="checkbox"/>

E-mail Send logs now

[Save Changes](#)

Figure 13: Configuration Event Log Tab

Configuration Admin Tab

The user can set the system clock and administrative information on this tab. Additionally the user can set administrator and account passwords. See Unit Configuration section for details.

Sensors

Alarms

Logging

Display

Config

Network

Monitoring

Diagnostics

Event Log

Admin

Control

Help

PGA / Phone | XML | HUB

Configuration

All Parameters

Reboot

RS2 Disclaimer

WARNING:

Please note that you are enabling this device to turn on or off electrical outlet(s) on RS2 unit(s).

Also note that the acceptance of these terms is saved in the XML configuration file on this device. If this file is used to configure another unit, then the acceptance of these conditions will carry over to that device as well.

There are no warranties, express or implied by this action, by the operation of law or otherwise, of enabling this feature. GEST DISCLAIMS ALL IMPLIED WARRANTIES OF MERCHANTABILITY, SATISFACTION, AND FITNESS FOR A PARTICULAR PURPOSE.

I Accept

System Clock, set to GMT

Set Clock method: NTP Server

GMT to local, (+/-)hh:mm -05:00

NTP primary server 192.43.244.18
192.43.244.18

NTP secondary server 129.6.15.28
129.6.15.28

Sync to NTP server period (seconds) 1800

Daylight Saving Time

DST is DISABLED

Enable DST: Disabled

Name and Password Configuration

NOTE 1: If Account currently has a password, leaving Old Password blank results in no changes to that account.
 NOTE 2: Administrator password may be used in the Old Password field of any account.
 NOTE 3: If setting New Password to blank, Account Name must also be blank.
 NOTE 4: If New Password is not blank, Account Name must not be blank.

Administrator Account Name:
 Old Password:
 New Password: (login to confirm)
 New Password Again: (login to confirm)
Warning: Record your password. Loss of password may require 18 hours to recover.

Control Account Name:
 Old Password:
 New Password: (login to confirm)
 New Password Again: (login to confirm)
Warning: Record your password. Loss of password may require 18 hours to recover.

View Only Account Name:
 Old Password:
 New Password: (login to confirm)
 New Password Again: (login to confirm)
Warning: Record your password. Loss of password may require 18 hours to recover.

Admin Info

Contact Name:

Contact Email: (ip>Contact)

Contact Phone:

Device Location: (ip/Location)

Device Description: (ip/Name)

Saved Configuration XML File

XML File: No file chosen

SSL Certificate and Private Key

SSL Certificate and Private Key are VALID

SSL Certificate File: No file chosen

SSL Private Key File: No file chosen

Upload System Firmware

Firmware package file: No file chosen

Figure 14: Configuration Admin Tab

Control Page

The *Control* page gives the user control of the low voltage output relays. The Watchdog 1400 Series units provide three output relays that can be operated remotely or set to automatically open or close based on alarm conditions. See Output Relays (page 26) for additional information.

Control

Relay Settings

Relay	Relay Name	Energized	De-energized	Mode ²
Relay-1	Relay-1	Lit	Dim	<input type="checkbox"/> Latching
Relay-2	Relay-2	Activated	Deactivated	<input type="checkbox"/> Latching
Relay-3	Relay-3	detonated	stand-by	<input checked="" type="checkbox"/> Latching

Save Changes

Manual Override

Relay	Status	Action
Relay-1	Dim	(Do Nothing)
Relay-2	Deactivated	(Do Nothing)
Relay-3	detonated	(Do Nothing)

Execute

Acknowledgments

Relay	Acknowledge & De-energize
Relay-3	<input type="checkbox"/>

Execute

Restore Relay Defaults

Restore Defaults

Figure 15: Control Actions Page

Control

Relay Settings

Relay	Relay Name	Energized	De-energized	Mode ²
Relay-1	Relay 1	Energized	De-energized	<input type="checkbox"/> Latching
Relay-2	Relay 2	Energized	De-energized	<input type="checkbox"/> Latching
Relay-3	Relay 3	Energized	De-energized	<input type="checkbox"/> Latching

Save Changes

Manual Override

Relay	Status	Action
Relay 1	De-energized	(Do Nothing)
Relay 2	De-energized	(Do Nothing)
Relay 3	De-energized	(Do Nothing)

Execute

Restore Relay Defaults

Restore Relay Configuration Defaults

Figure 16: Control IO Expander Page

Unit Configuration

Network Configuration

The unit's network configuration is set on the *Network* tab of the *Configuration* page. Settings pertaining to the unit's network connection are:

Configuration

Network

Current Network Configuration set statically
Link Speed: **10Mbps/half-duplex**

Use **DHCP** for Network Configuration and DNS Server Addresses
 Use **DHCP** for Network Configuration and **Static** DNS server addresses:
 Use **Static** Network Configuration and DNS server addresses:

IP Address:
Subnet Mask:
Gateway:
Primary DNS Server:
Secondary DNS Server:

Web Server

Protocols:
HTTP Port:
HTTPS Port:
Telnet Service:

Figure 17: Network Configuration

- **DHCP:** Allows the unit to request a dynamic IP address from a server on the network.
- **Static IP Address/Net Mask/Gateway:** When not using a dynamic address, enter static network configuration information here.

Telnet Service: Enable or disable the built-in Telnet server. See

- Telnet (page 24) for details.
- **HTTP Services:** Enables/disables access via HTTP and HTTPS. Available options are: HTTP and HTTPS, HTTP only, and HTTPS only. It is not possible to disable the web interface completely.
- **HTTP/HTTPS Server Port:** Changes the TCP port that each server listens on.
- **DNS Servers:** Allows the unit to resolve host names for Email, NTP and SNMP servers as well as cameras.

Time and Date

The system clock is set on the *Admin* tab of the *Configuration* page. The unit comes preconfigured with the IP addresses of two NIST time servers and is set to the Central Time Zone (-0500 GMT). Should a local time server be preferred, enter its IP address into the "NTP primary server" box and click the "Save Changes" button. Clearing the time server addresses and clicking "Save Changes" will set the time servers back to the defaults. The unit attempts to contact the time servers during boot up and periodically while running. Until a time server is contacted or the system clock is manually set, all log time stamps will present time as the number of seconds since the unit was powered up and graphs will not be shown.

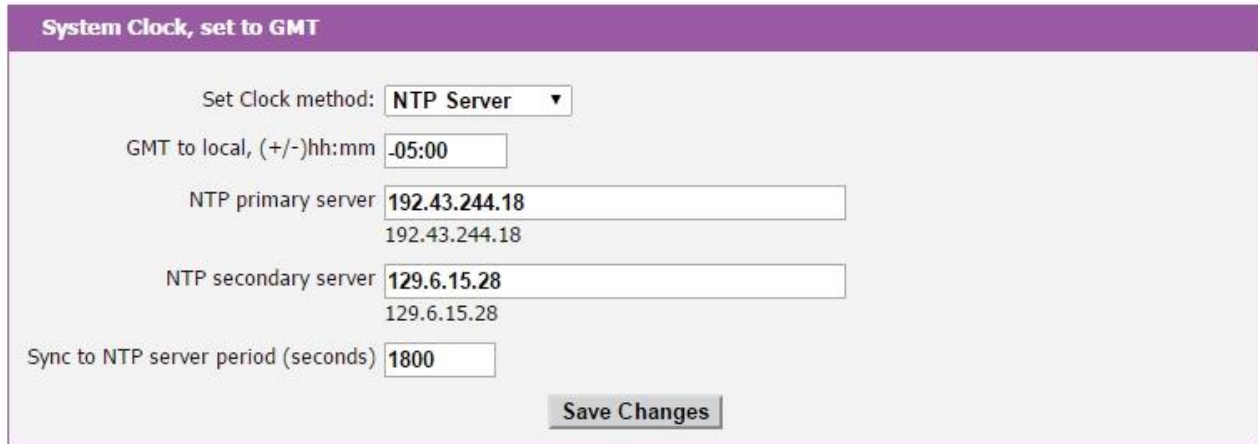

Figure 18: Time Settings

The time, date, IP address and friendly name of the unit are displayed in the top of each web page.



Figure 19: Time and Date Display

Note: The time and date are not adjusted for daylight savings time. Setting the time zone offset forward and backward an hour will cause a gap or overwriting of logs, respectively.

E-Mail

The unit is capable of sending e-mail to as many as five addresses at once. Most SMTP and ESMTP servers are compatible. Authentication options are None, POP3 (POP-before-SMTP) or ESMTP. The e-mail configuration is set on the *Monitoring* tab of the *Configuration* page.

E-mail

Protocols: **No Authentication (email relay)** ▾

SMTP Server:

SMTP Port:

"From" E-mail Address:

Send alarms to this recipient:

	Always	Business Hours?	After Hours?	SMS?
To E-mail Address 1: <input type="text"/>	<input checked="" type="radio"/>	<input type="radio"/>	<input type="radio"/>	<input type="checkbox"/>
To E-mail Address 2: <input type="text"/>	<input checked="" type="radio"/>	<input type="radio"/>	<input type="radio"/>	<input type="checkbox"/>
To E-mail Address 3: <input type="text"/>	<input checked="" type="radio"/>	<input type="radio"/>	<input type="radio"/>	<input type="checkbox"/>
To E-mail Address 4: <input type="text"/>	<input checked="" type="radio"/>	<input type="radio"/>	<input type="radio"/>	<input type="checkbox"/>
To E-mail Address 5: <input type="text"/>	<input checked="" type="radio"/>	<input type="radio"/>	<input type="radio"/>	<input type="checkbox"/>

Figure 20: E-Mail Configuration

An SMTP server as well as "From" and "To" addresses are required to send e-mails. Some mail servers may require a username and password. In most cases, the username does not have to match the "From" address, but does need to be a valid user on the authenticating server. Microsoft Exchange servers will have to be set to allow SMTP relay from the IP address of the unit. In addition, a test email can be sent from the bottom of the *Monitoring* tab of the *Configuration* page.

Note: The unit cannot receive e-mails. The POP3 server is used strictly for authentication and is not required when using None or ESMTP.

Status Reports

When enabled, the unit will periodically send a full status report to all "To" e-mail addresses selected for the report. The report includes current unit data from all attached sensors as well as alarm states. Reporting frequency options are: weekly, hourly, every 2, 3, 4, 6, 8, 12, 24, or 48 hours. E-mail addresses are selected by checking the corresponding e-mail destination box when the report is created. Allowing the cursor to hover over an e-mail destination box will display the e-mail address that the box is associated with.

System Status E-Mail Reports

Report Time: hour min
(0-23) (0-59)

Report Period: ▾

E-mail Destinations:

Delete This Report:

Figure 21: Email Report Settings

SNMP

The unit supports retrieval of all data via Simple Network Management Protocol (SNMP) v1, v2c, and v3. In addition, alarm traps can be sent to up to two IP addresses. The SNMP configuration is entered on the *Monitoring* tab of the *Configuration* page.

The image shows two web forms for SNMP configuration. The top form, titled "SNMP", includes the following fields: "SNMP Service" (dropdown menu set to "Enabled"), "Temperature Precision" (dropdown menu set to "1x degree C/F"), "Read Community" (text input field with "public"), "Listen port for GET" (text input field with "161"), "Trap Community" (text input field with "private"), "Write Community" (text input field with "private"), "Trap Type" (dropdown menu set to "V1 Trap"), "Trap IP Address:port 1" (text input field), and "Trap IP Address:port 2" (text input field). Below these fields are two buttons: "Save Changes" and "Send Test SNMP Trap?". The bottom form, titled "Initial SNMPV3 data", includes the following fields: "Unauthenticated User" (text input field with "initial"), "Authenticated Manager" (text input field with "manager"), "Manager Authentication Password" (text input field with "12345678"), "Manager Privacy Password" (text input field with "12345678"), "Trap User" (text input field with "Trap"), "Trap Authentication Password" (text input field with "12345678"), and "Trap Privacy Password" (text input field with "12345678"). A "Save Changes" button is located at the bottom of this form.

Figure 22: SNMP Configuration

The default community string is "public" and the MIB is downloadable via a link on the unit's web page.

Accounts and Passwords

Watchdog 1400 Series offer account security options that are entered on the *Admin* tab of the *Configuration* page. There are three levels of account security:

- **Administrator:** Password protects the Display, Alarms and Configuration pages.
- **Control Access:** Password protects the Control Actions and Control Settings pages.
- **View-Only:** Password protects the Sensors, PDA, WAP and XML pages.

Name and Password Configuration

NOTE 1: If Account currently has a password, leaving Old Password blank results in no changes to that account.
 NOTE 2: Administrator password may be used in the Old Password field of any account.
 NOTE 3: If setting New Password to blank, Account Name must also be blank.
 NOTE 4: If New Password is not blank, Account Name must not be blank.

Administrator Account Name?
 Old Password
 New Password
 New Password Again (again, to confirm)
 Warning: Record your password. Loss of password may require 48 hours to recover.

Control Account Name?
 Old Password
 New Password
 New Password Again (again, to confirm)
 Warning: Record your password. Loss of password may require 48 hours to recover.

View Only Account Name?
 Old Password
 New Password
 New Password Again (again, to confirm)
 Warning: Record your password. Loss of password may require 48 hours to recover.

Save Changes

Figure 23: Account Configuration

User account names may include alphanumeric characters, spaces and underscores. Passwords may include alphanumeric characters and underscores.

Note: The Administrator account must be active to enable the Control Access and View-Only accounts.

Note: The Control Access account must be active to enable the View-Only account.

Note: The account names "root" and "admin" are disabled for security reasons and cannot be re-enabled.

Warning: Record your passwords. To reset lost passwords, follow the instructions for resetting the unit's IP address and passwords given in the Default IP Address section. To generate a temporary recovery password to access the unit, contact customer service from a location where the unit can be accessed via the Internet.

Telnet

The unit provides a Telnet server for basic monitoring via the command line. The Administrator account must be enabled to use the Telnet interface. Type "help" after logging in to the unit to see a list of available commands. The Telnet service can be disabled under "Web Server" on the *Network* tab of the *Configuration* page.

Note: All data sent via Telnet is unencrypted. Some settings can be changed and user names and network settings are available via Telnet. In secure environments, it is recommended that Telnet be disabled.

Camera Configuration

Enter the domain names/IP addresses and models of up to four IP-addressable network cameras in the "Cameras" section of the *Monitoring* tab on the *Configuration* page. The unit will present a linked snapshot from each camera on the *Sensors* page.

Cameras

Cam 1, IP Address:
 Model:
 Username:
 Password:

Cam 2, IP Address:
 Model:
 Username:
 Password:

Cam 3, IP Address:
 Model:
 Username:
 Password:

Cam 4, IP Address:
 Model:
 Username:
 Password:

Figure 24: Configuration and Supported Models

Note: Each camera must be set to allow anonymous access to enable this feature.

Admin Information

Information entered in the “Admin Info” section of the *Admin* tab of the *Configuration* page will show up at the bottom of the unit’s web interface.

Admin Info

Contact Name:
 Contact Email: (sysContact)
 Contact Phone:
 Device Location: (sysLocation)
 Device Description: (sysName)

Figure 25: Admin Information Fields

Unit Location: Somewhere
 Unit Description:
 Admin: John Doe or Call 000.123.5678
 Support: Manuals, support@geistglobal.com or Call 800.432.3219 / +1.402.474.3400
 Copyright © 2003-2015 Geist All Rights Reserved.

Figure 26: Admin Information Display

Output Relays

Relay Contact Ratings

The output relay contacts are intended to carry low voltage signals only. Do not exceed the following ratings on the output relay contacts:

DC: 60 V, 30 W

AC: 30 Vrms, 1 A

Relay Settings

The Watchdog 1400 Series units provide three output relays that can be operated remotely or set to automatically open or close based on alarm conditions. A relay in non-latching mode will automatically energize and de-energize as its associated alarms trip and clear. A relay in latching mode will similarly energize on an alarm trip, but will only de-energize when acknowledged by the user. See Alarms (page 28) for additional information on associating an alarm condition with one of the output relays.

Manual Override

The three output relays can be operated remotely through the Manual Override section of the *Control* page. The user can force the relay to energize or de-energize by selecting the desired action in a drop down menu and clicking the execute button. The current relay status is displayed in the Manual Override section of the *Control* page. The word "forced" is displayed next to any relay that has been manually forced to a given state. Any forced relay will not change state based on alarm status. Relays can be released from a forced energized or forced de-energized state by selecting the Release Override option in the drop down menu.

Acknowledgments

Any relay in latching mode will change from de-energized to energized if it receives an alarm trip; however, the relay will not change from energized to de-energized when the alarm status returns to normal until the user acknowledges the pending change. Similarly, any relay in latching mode will change from de-energized to energized if it receives a manual override Force Energized command; however, the relay will not change from energized to de-energized when the Release Override command is issued until the user acknowledges the pending change. The user must check the Acknowledge and De-energize box on the *Control* page for a latched relay to de-energize.

- Sensors
- Alarms
- Logging
- Display
- Config
- Control**
- Actions
- IO Expander
- Help

PDA/Phone | XML | MIB

Control

Relay Settings

Relay	Relay Name	Energized	De-energized	Mode?
Relay-1	Relay-1	Lit	Dim	<input type="checkbox"/> Latching
Relay-2	Relay-2	Activated	Deactivated	<input type="checkbox"/> Latching
Relay-3	Relay-3	detonated	stand-by	<input checked="" type="checkbox"/> Latching

Save Changes

Status Labels

Relay Status

Manual Override

Relay	Status	Action
Relay-1	Dim	(Do Nothing)
Relay-2	Deactivated	(Do Nothing)
Relay-3	detonated	(Do Nothing)

Execute

Manual Override Actions

Acknowledgments

Relay	Acknowledge & De-energize
Relay-3	<input type="checkbox"/>

Execute

Restore Relay Defaults

Restore Defaults

Figure 27: Relay Control Options

Alarms

Alarm Notifications

The Watchdog 1400 supports four types of alarm notification:

- **Relay:** The unit can be configured to energize up to three control relays
- **E-Mail:** The unit can be configured to send alarm e-mails to up to five recipients.
- **SNMP:** The unit can be configured to send SNMP traps to up to two trap servers.
- **Buzzer:** The unit supports an additional audible alarm notification.

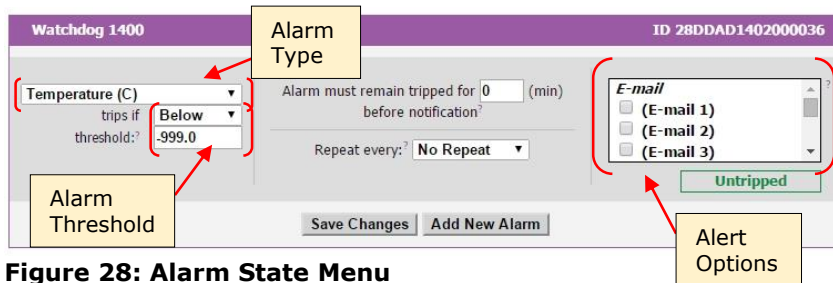

Figure 28: Alarm State Menu

The unit is capable of any combination of the above alarms at once. Alarm type combinations are selected per alarm via the check boxes which are displayed for each alarm on the Alarms page.

Alarm Types

The Watchdog 1400 provides three types of alarm messages via E-Mail and SNMP:

- **Trip:** Occurs when a sensor value goes above a high trip threshold or below a low trip threshold.
- **Clear:** Occurs when a sensor already in the Tripped or Unplugged state goes back into its normal range.
- **Unplugged:** Occurs when a sensor with an alarm set loses contact with the main unit due to the sensor being physically unplugged or another communications error.

Alarms can be added for each internal device or external sensor displayed on the Alarms page. An alarm is added by pressing the "Add New Alarm Button" and selecting the sensor value to be monitored from a drop down menu.

Thresholds

The user must set a trip threshold and type for each alarm that is added to the Alarms page. The threshold type is chosen as either "High Trip" or "Low Trip" from a drop down menu when the alarm is created. The threshold value is typed into a data window when the alarm is created. Alarms are triggered based on the selected sensor's data and the trip threshold type and value. Alarm settings can be edited or deleted at any time.

Analysis of each unit is recommended before setting alarm thresholds as some of the values monitored by the unit are relative values whose scale will differ slightly between units. Allow each unit to operate under normal, steady-state conditions for several hours before setting alarm thresholds. By allowing the sensors to operate for several hours, the user can better understand what the normal variations are; thereby allowing the user to choose alarm thresholds that will not trigger numerous false alarms.

Note: Changes in settings take a few moments to become active. Rapidly resetting alarm values may not provide the desired results. Allow up to 2 minutes after changing a setting before modifying it again.

Sensors

Overview

All internal sensors are measured every 5 seconds. External sensors are measured every 10 to 30 seconds, depending on the number of devices connected. Sensor data collected by Watchdog 1400 units provides useful trend analysis data. While all values are not absolute in relation to a known unit, trend analysis of the data allows users to view changes and draw useful conclusions about what is happening over time in the monitored environment.

Internal Sensors

Watchdog 1400 units contain the following onboard sensors:

- **Temperature:** Measures temperature and can be displayed in °C or °F. The accuracy is ± 1 °F from -50 °F to 185 °F. Note: This sensor may be heated by internal circuitry in the unit; a temperature offset is available to re-calibrate.
- **IO-1:** Scales 0 to 5 Vdc input to a set Min and Max, dry contacts may be used.
- **IO-2:** Scales 0 to 5 Vdc input to a set Min and Max, dry contacts may be used.
- **IO-3:** Scales 0 to 5 Vdc input to a set Min and Max, dry contacts may be used.
- **IO-4:** Scales 0 to 5 Vdc input to a set Min and Max, dry contacts may be used.
- **IO-5:** Scales 0 to 5 Vdc input to a set Min and Max, dry contacts may be used.
- **IO-6:** Scales 0 to 5 Vdc input to a set Min and Max, dry contacts may be used.

I/O Sensors

The Watchdog 1400 units come equipped with six I/O ports for connecting additional external sensors such as Water and Door Sensors. The six ports are designed to accept a 0-5 Vdc analog input; alternatively, an internal 100K pull up resistor to 5 V allows for the use of dry contacts. The I/O port input is linearly converted to a digital number range between a set Minimum and Maximum (0 to 99 is Default) and is displayed on the *Sensors* page. Unused I/O ports will display the Max set value. Setting the Min, Max and Units will give the user more useful data depending on the sensor being used.

Sensor	Friendly Name	Min	Max	Unit
IO-1	Analog-1	0.000	99.000	
IO-2	Analog-2	0.000	99.000	
IO-3	Analog-3	0.000	99.000	
IO-4	Analog-4	0.000	99.000	
IO-5	Analog-5	0.000	99.000	
IO-6	Analog-6	0.000	99.000	

Save Changes

Analog Sensor Scale Adjustment

Figure 29: Analog Sensor Settings

Sensor Examples:

Water sensors act as conductivity bridges. Moisture across the contacts causes the value to drop. Door switches can be wired in a serial connection; if the chain is broken the entire group is classified as open. The limiting factor on the I/O ports is the length of the wire, found to be around 400 feet.

Water Sensors

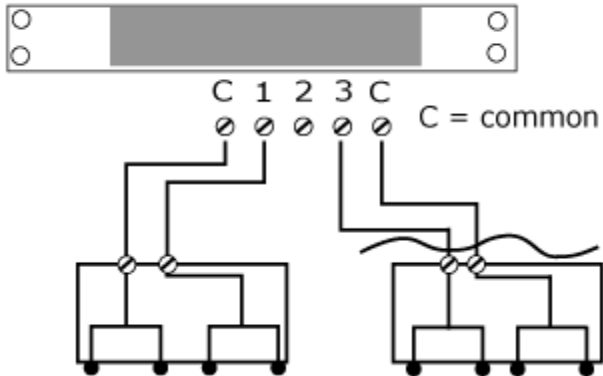

Figure 30: Water Sensor Wiring Example

Door Switches - Extended

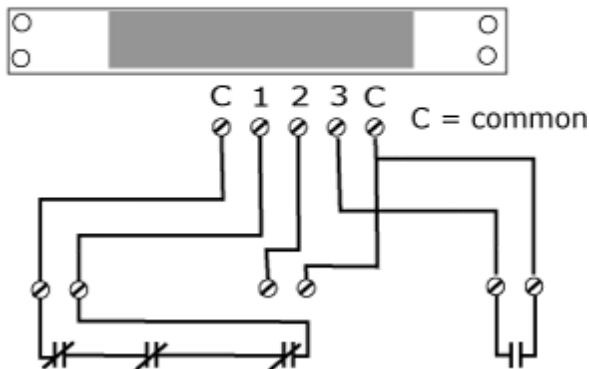

Figure 31: Door Sensor Wiring Example

Additional Optional I/O Sensors

- **RWS:** Water Sensor
- **RDPS:** Door Sensor
- **SA-1:** Smoke Alarm
- **RCP-2:** 125 V City Power Monitor
- **WSK-10:** 10' Water Sensing Cable Kit
- **WSK-40:** 40' Water Sensing Cable Kit
- **-48 VDCM:** Power Monitor
- **30 VDCM:** Power Monitor

Remote Sensors

Available Sensors

- **RT:** Temperature
- **THD:** Temperature / Humidity / Dew Point
- **T3HD:** Temperature / Humidity / Dew Point with ability to add two RT sensors
- **RTAFHD3:** Temperature / Air Flow / Humidity / Dew Point
- **CCAT:** Converts analog I/O Sensors to Remote Digital Sensors

*RTAF, RTAFH & RTHD sensors have been discontinued and replaced by the RTAFHD3 sensor. Some Geist R-Series devices may require a firmware update to allow for proper compatibility with the new RTAFHD3 sensors.

If your Geist R-Series device is using firmware version 2.xx you will want to make sure you are using firmware version 2.94 or newer.

If your Geist R-Series device is using firmware version 3.xx you will want to make sure you are using firmware version 3.5.0 or newer.

Please contact Geist Support at 800-432-3219 if you need assistance locating your current version or upgrading to the new firmware version.

RTAFHD3 Compatibility

The (G)RTAFHD3 sensor cannot be utilized in combination with the discontinued (G)RTAF and (G)RTAFH sensors or (G)RTHD sensors built prior to 2010. If you desire to add (G)RTAFHD3 sensors to an existing installation currently utilizing incompatible sensors, please contact Customer Service for installation options.

Connecting Remote Sensors

Plug-and-play remote sensors may be attached to the unit at any time via the RJ-12 connectors on the face of the unit. In some cases splitters may be required to add additional sensors. Each sensor has a unique serial number and is automatically discovered and added to the web page. Up to sixteen sensors may be connected.

The display order of the sensors on the web page is determined by the serial number of each sensor. Friendly names for each sensor can be customized on the *Display* page.

Note: The sensor uses Cat. 3 wire and RJ12 connectors. Wiring must be straight-through: reverse polarity will temporarily disable all sensors until corrected.

Note: The sensors use a serial communication protocol and are subject to network signaling constraints dependent on shielding, environmental noise, and length of wire. Typical installations allow runs of up to 600 feet of sensor wire.

Data Logging and Display

All data collected by the unit can be graphed. The *Logging* page allows the user to select graphed content to be logged. Selected sensor values are logged into the data file at a rate of one point per minute and will be displayed on the unit's LCD display. The number of selected sensors determines the maximum data logging time span. This period is calculated and displayed on the *Logging* page. The oldest data will be deleted when the onboard memory fills up in order to make room for new data.

Accessories

IP-Addressable Network Cameras

The unit is able to interface with up to four IP-addressable network cameras. A live snapshot from each camera will be displayed on the unit's *Sensors* page underneath the main unit's graph. Clicking on a snapshot opens the camera's website in a new browser window.



Figure 32: Camera Images

Camera model and IP address are entered on the *Monitoring* tab of the *Configuration* page.

Note: Some cameras require additional software downloads to display live video in a web browser.

RSC Integration

For users with multiple units, Geist RSC software offers:

- Convenient, single-window monitoring of multiple units via simple web-based interface
- Streamlined firmware updating
- Consolidation of alarm settings

See <http://www.geistglobal.com> for more information.

Alternate Data Formats

In addition to the full access, control and configuration available via a desktop web browser, Watchdog 1400 Series products present data in multiple formats for easy integration with other monitoring systems. Data formats available via links on the unit's web page are:

[PDA/Phone](#) | [XML](#) | [MIB](#)

Figure 33: Alternate Format Links

- **PDA/Phone:** Presents data in a format best-suited for PDA or cellular phone web browsers.
- **XML:** Extensible Markup Language. Presents data in a structured tree for use with automated scripts and monitoring systems.
- **MIB:** Management Information Base. Downloads the MIB for use with SNMP monitoring tools.

Technical Support

Firmware Version

The firmware version is located in the upper right section of the web interface header, represented by v3.y.xx. Before contacting support, it is recommended that the Watchdog 1400 unit first be updated to the latest firmware version. If this is not possible, please have the unit's existing firmware version number available when contacting technical support.

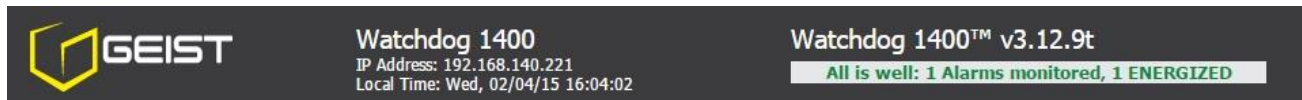

Figure 34: Web Page Header

Firmware Updates

Keep your unit updated with the latest firmware releases or sign up for notifications at the following website: <http://www.geistglobal.com/support/monitor/firmware>.

Resetting the Unit

Should the Watchdog 1400 unit lose communication; the processor may be manually rebooted by pressing the 'Reboot' button on the face of the unit. The web interface will remain off-line and any energized relays will be de-energized during boot up.

Service and Maintenance

No service or maintenance is required. Do not attempt to open the unit or you may void the warranty. No serviceable parts inside.

More Technical Support

<http://www.geistglobal.com>
(800) 432-3219
Email: support@geistglobal.com
Or contact your distributor.

Table of Figures

Figure 1: 19" Horizontal/Panel Mount Brackets (7938)	5
Figure 2: Network settings for initial setup. Images varies depending on Windows versions.	6
Figure 3: Mac OS network settings for initial setup. Image varies depending on Mac versions.	7
Figure 4: Sensors Page – Internal Sensor and I/O Data	8
Figure 5: Sensors Page – External Sensor Data	9
Figure 6: Logging Page	10
Figure 7: Display Main Page	11
Figure 8: Display IO Expander Page.....	12
Figure 9: Alarms Page	13
Figure 10: Configuration Network Tab.....	14
Figure 11: Configuration Monitoring Tab	15
Figure 12: Configuration Diagnostics Tab	16
Figure 13: Configuration Event Log Tab	17
Figure 14: Configuration Admin Tab	18
Figure 15: Control Actions Page	19
Figure 16: Control IO Expander Page	19
Figure 17: Network Configuration.....	20
Figure 18: Time Settings	21
Figure 19: Time and Date Display	21
Figure 20: E-Mail Configuration.....	22
Figure 21: Email Report Settings.....	22
Figure 22: SNMP Configuration	23
Figure 23: Account Configuration	24
Figure 24: Configuration and Supported Models	25
Figure 25: Admin Information Fields.....	25
Figure 26: Admin Information Display.....	25
Figure 27: Relay Control Options.....	27
Figure 28: Alarm State Menu	28
Figure 29: Analog Sensor Settings.....	29
Figure 30: Water Sensor Wiring Example	30
Figure 31: Door Sensor Wiring Example	30
Figure 32: Camera Images	32
Figure 33: Alternate Format Links	32
Figure 34: Web Page Header	33

Revision History

Revision	Date	Notes	Approved By
1.0	10/20/2009	Initial Version	BGP, JP, AK
1.1	7/1/2010	Minor Text Edits	BGP
1.2	10/15/2010	RTAFHD3 Information Added	BGP
1.3	3/21/2011	Allow for only 6V DC power supply	CDG, BGP
1.4	4/27/2012	Added THD and T3HD	CG
1.5	6/7/2012	Logo and website update	CG
1.6	6/26/2013	Added 'G' to the product Number	SR
2.0	2/4/2015	Change product name, screenshots, and update product information	QN